

PiezoDrive

MX200 V10 200V 1A Piezo Driver



The MX200 is a complete power supply and high-performance linear amplifier module for driving piezoelectric actuators. The MX200 can drive stack actuators; standard piezoelectric actuators; two wire benders; and three-wire piezoelectric benders requiring a bias voltage. Output currents of up to 1 Amp are developed at frequencies up to 100 kHz with less than 100 μV noise (10Hz to 10kHz). Bipolar output voltages up to +/-100V are possible with an external AC coupling capacitor.

The MX200 is protected against short-circuit, average current overload, and supply under-voltage. The MX200 can be used as a stand-alone module or mounted to a base with four M3 screws. The PCB mounting version (MX200-PCB) is supplied with headers for direct mounting onto a host motherboard.

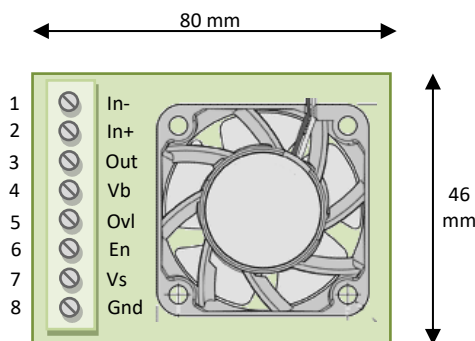

Inputs		Outputs	
In-	Neg. Input	Out	HV Output
In+	Pos. Input	Vb	Bias Voltage
Gnd	Ground	Ovl	Overload
En	Enable		
Vs	Supply		

Specifications	
Power Supply	24V (18V to 36V)
Voltage Range	+100V, +150V, +200V
Peak Current	1 Amp
RMS Current	550 mA, 330 mA, 220 mA
Power Bandwidth	106 kHz (180 Vp-p)
Signal Bandwidth	200 kHz (100nF Load)
Slew Rate	60 V/us
Gain	20 V/V
Input Impedance	33 k Ω (In+), 1.6 k Ω (In-)
Input Offset	± 5 mV
Load	Unlimited
Output Noise	<100 μV RMS (10Hz to 10kHz)
Protection	Short-circuit, average current, and under-voltage protection
Quiescent Current	0.3 A (30 mA in Shutdown)
Dimensions	80 x 46 x 40 mm (L x W x H)
Environment	0 to 60°C (32 to 140°F) Non-condensing humidity
Weight	95 g

Operation

The system block diagram is illustrated in Figure 2. A boost converter generates the high voltage supply and negative rail. The output voltage range can be set to either +100V, +150V, or +200V. Configuration options are discussed in "Configuration". Bipolar output voltages up to +/-100V are possible with an external AC coupling capacitor, refer to "Bipolar Output Voltage".

The high-voltage amplifier has differential inputs with a gain of 20 and an input voltage range of 10 V. The negative input can be connected to ground or to a differential source. It should not be left floating.

The load is connected between the output and ground. The bias voltage output is for three wire bimorph bender actuators.

Figure 1. Connection diagram

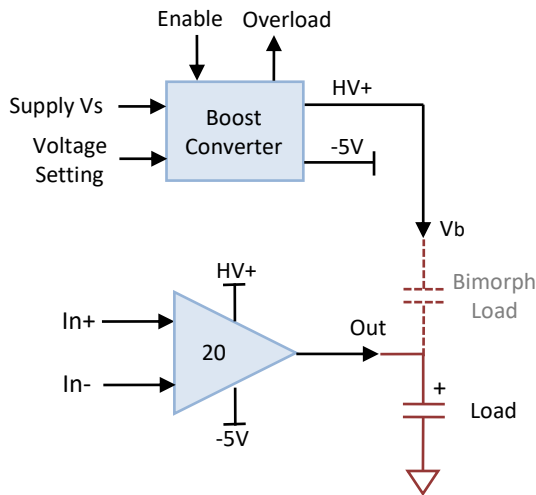

Figure 2. MX200 Block Diagram

Configuration

The output voltage range can be set to either +100V, +150V or +200V using the two jumpers LK1 and LK2. Greater output current is available in the lower voltage ranges, as described in Table 1. Incorrect jumper combinations will damage the amplifier.

Output Voltage	Peak Current	RMS Current	Average Current	LK1	LK2
100 V	1 A	550 mA	250 mA	A	Out
150 V	1 A	330 mA	150 mA	B	B
200 V	1 A	220 mA	100 mA	Out	A

Table 1. Voltage Range Jumper Settings

Output Current

The peak output current is 1 Amp for all voltage ranges but the maximum continuous RMS current is dependent on the voltage range, as described in Table 1. The average positive output current is also useful for calculating power dissipation and the average supply current. For a sine wave, the average positive output current is equal to

$$I_{av} = \frac{\sqrt{2}}{\pi} I_{rms} = \frac{1}{\pi} I_{pk}$$

Supply Current

The quiescent power for the amplifier and fan is approximately 8 W. Therefore, the quiescent supply current at 24 V is 0.3 A. This can be reduced to <30 mA by applying a logic zero to the Enable pin. The supply current is related to the average positive output current by

$$I_s = \frac{1.1 \times V_{out} \times I_{av} + 8}{V_s}$$

where V_{out} is the output voltage range, and I_{av} is the average output current. Therefore, the maximum supply

current is 1.25 A with a 24 V supply at the full rated power ($I_{av} = 100$ mA).

The power supply must be sufficient for the amplifier, a rating of at least 1.5 Amps is recommended. Note that when power is first applied or when the amplifier is enabled, full current will be required for a brief period to charge the storage capacitors.

Applications Circuits

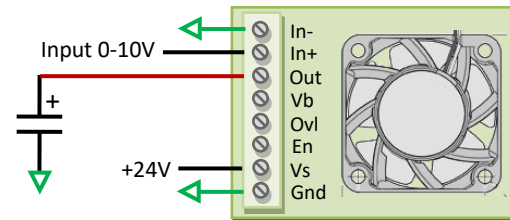

200 V Piezo stack driver.

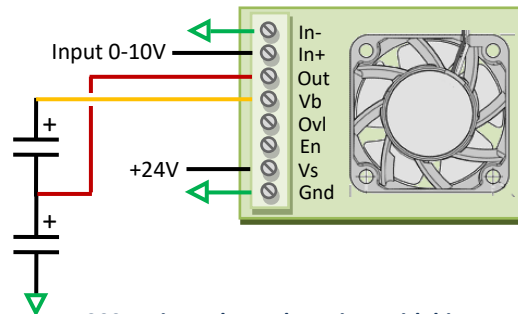

200 V Bimorph Bender Driver with bias.
Also suitable for benders with +100V and -100V bias.

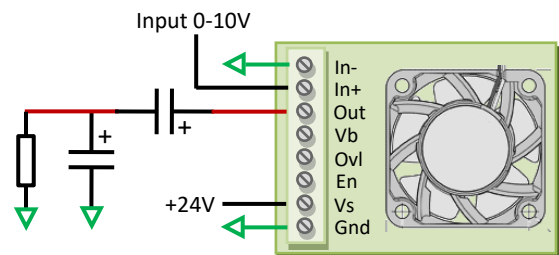

+/-100 V Piezo Driver, see "Bipolar Output Voltage".

Bias Output for Piezo Bimorphs

The bias output (Vb) provides a fixed voltage for driving three-wire piezoelectric benders. The bias voltage is approximately 5V above the selected voltage range. The effective capacitance when using bimorph actuators is the sum of both layers.

Actuators that require a symmetrical bias voltage, e.g. ± 100 V can also be driven since this configuration is electrically identical to the unipolar configuration, e.g. 0V to 200V.

Power Bandwidth

The nominal slew-rate of the MX200 is 60 V/us. Therefore, the maximum frequency sine-wave is

$$f_{max} = \frac{60 \times 10^6}{\pi V_{L(p-p)}}$$

The unloaded power bandwidth for each voltage range is listed in Table 2.

Voltage Range	Power Bandwidth
200 V	95 kHz
150 V	127 kHz
100 V	190 kHz

Table 2. Unloaded power bandwidth

With a capacitive load, the power bandwidth is limited by the output current. The maximum frequency sine wave is

$$f_{pwr} = \frac{I_{av}}{V_{L(p-p)} C_L}$$

where I_{av} is the average current limit, $V_{L(p-p)}$ is the peak-to-peak output voltage, and C_L is the effective load capacitance. The power bandwidth for a range of load capacitance values is listed in Table 3.

Load (uF)	Voltage Range		
	100 V	150 V	200 V
0.01	190000	100000	50000
0.03	83333	33333	16667
0.1	25000	10000	5000
0.3	8333	3333	1667
1	2500	1000	500
3	833	333	167
10	250.0	100.0	50.0
30	83.3	33.3	16.7

Table 3. Power bandwidth (in Hz) with a capacitive load

In the following figures, the maximum peak-to-peak voltage is plotted against frequency for each voltage range.

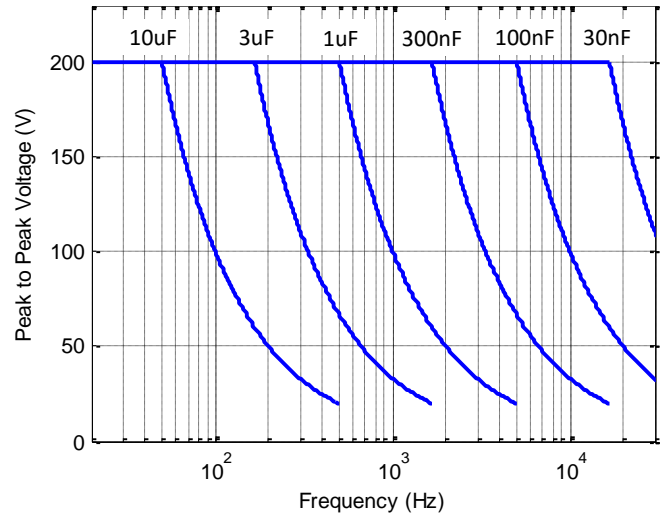

Figure 3. Power Bandwidth (200V Range)

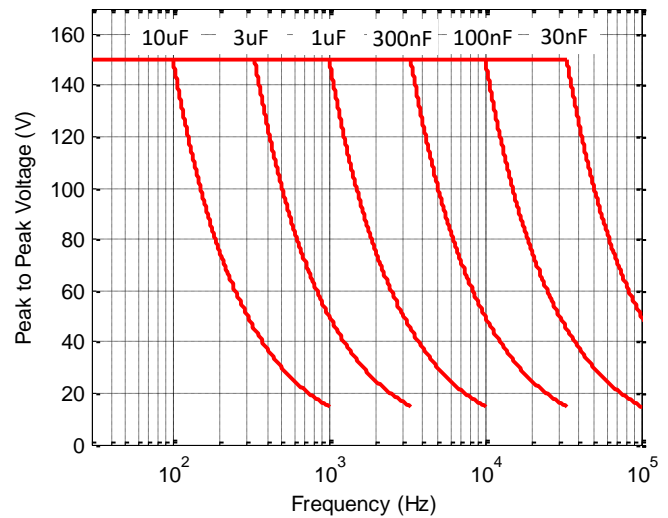

Figure 4. Power Bandwidth (150V Range)

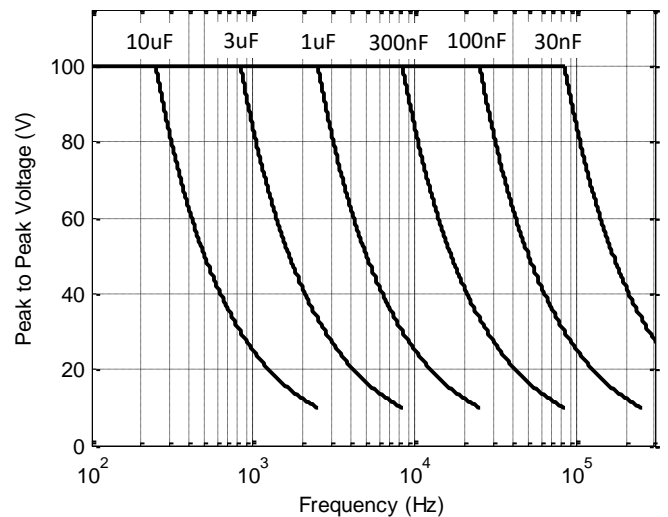

Figure 5. Power Bandwidth (100V Range)

Signal Bandwidth

The small-signal bandwidth for a range of capacitive loads is listed in Table 4. The small-signal frequency responses are plotted in Figure 6.

Load Capacitance	Signal Bandwidth
10 nF	180 kHz
30 nF	283 kHz
100 nF	275 kHz
300 nF	160 kHz
1 uF	78 kHz
3 uF	30 kHz
10 uF	8.3 kHz
30 uF	3.0 kHz

Table 4. Small signal bandwidth (-3 dB)

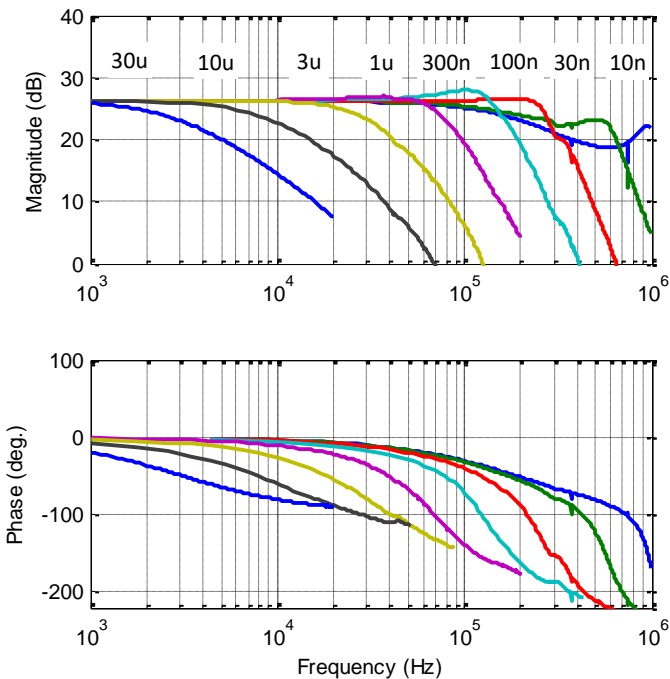

Figure 6. Small signal frequency response

Noise

The output noise contains a low frequency component (0.03 Hz to 10 Hz) that is independent of the load capacitance; and a high frequency component (10 Hz to 1 MHz) that is inversely related to the load capacitance.

Note that many manufacturers quote only the AC noise measured by a multimeter (20 Hz to 100 kHz) which is usually a gross underestimate.

The noise is measured with an SR560 low-noise amplifier (Gain = 1000), oscilloscope, and Agilent 34461A Voltmeter. The low-frequency noise is plotted in Figure 7. The RMS value is 360 uV with a peak-to-peak voltage of 1.8 mV.

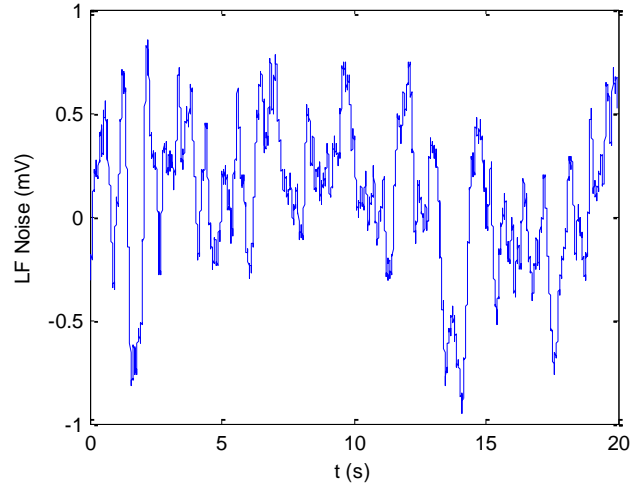

Figure 7. Low frequency output noise (0.03 Hz to 10 Hz)

The high frequency noise (10 Hz to 1 MHz) is listed in the table below versus load capacitance. The total noise from 0.03 Hz to 1 MHz is found by summing the RMS values, that is $\sigma = \sqrt{\sigma_{LF}^2 + \sigma_{HF}^2}$.

Load Capacitance	HF Noise	Total Noise
10 nF	1.5 mV	1.5 mV
30 nF	2.6 mV	2.6 mV
100 nF	3.5 mV	3.5 mV
300 nF	1.2 mV	1.3 mV
1 uF	306 uV	470 uV
3 uF	129 uV	380 uV
10 uF	100 uV	370 uV
30 uF	120 uV	380 uV

Table 5. HF Noise (10 Hz to 1 MHz) and total noise

The majority of high-frequency noise is due to ripple from the boost converter (at 170 kHz). In ultra-low noise applications, the output bandwidth can be restricted to 10 kHz which reduces the noise to less than 100 uV RMS in the 10 Hz to 1 MHz frequency range. This can be achieved with the RLC filter shown below.

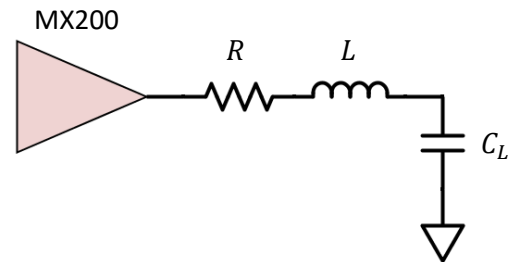

Figure 8. Output noise filter

The required inductance and resistance is

$$L = \frac{1}{4\pi^2 f_c^2 C_L} \quad \text{and} \quad R = 1.4\sqrt{L/C_L}$$

where f_c is the cut-off frequency (10 kHz) and C_L is the load capacitance. The inductor should be rated for at least 1 A with a self-resonance frequency of greater than 1 MHz.

A first-order resistive filter can also be effective, although it must be rated for the expected RMS current. The required value is

$$R = \frac{1}{2\pi f_c C_L}$$

Overload Protection / Shutdown

The MX200 is protected against short-circuit and average current overload. The module is also disabled when the input supply voltage is less than 12 V. Current overload conditions are signalled by +5 V on the Overload pin.

The amplifier can be shutdown manually by pulling the Enable pin low with an open-collector, or open-drain circuit. The Enable pin normally floats at 6.2V and should not be driven directly.

Bipolar Output Voltage

Bipolar output voltages can be achieved by adding an external AC coupling capacitor, as shown in the diagram below. This approach creates a high-pass filter with a cut-off frequency of 1 Hz. i.e., frequencies below 1 Hz will be strongly attenuated.

Up to +/-100V can be obtained using the 200V range, or +/-75V using the 150V range, or +/-50V using the 100V range.

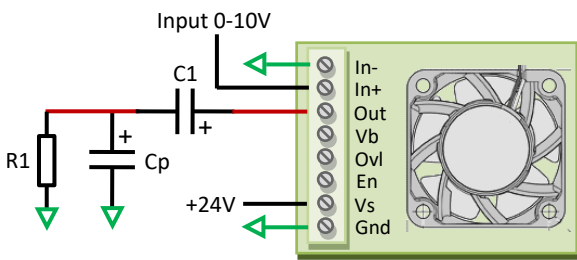

+/-100 V Piezo Driver, using an external capacitor C1 and resistor R1.

C1 should be rated for at least the full output voltage of the amplifier. For example, to achieve +/-100V using the 200V configuration, a 250V rated capacitor is required. The capacitance of C1 should be large enough to ensure the series voltage drop is less than 1% of the output voltage. Film capacitors are preferred but electrolytic capacitors are also suitable.

If the load is a piezo or capacitor, $C1 > 100 \times C_p$.

If the load is not capacitive at the operating frequency, the impedance of C1 should be less than 1% of the load impedance Z_p , that is,

$$C1 > \frac{100}{2\pi f |Z_p|}$$

The resistor R1 sets the AC coupling frequency f_{ac} , which is recommended to be 1 Hz. The value of R1 is

$$R1 = \frac{1}{2\pi f_{ac} C1}$$

The power rating of R1 should be greater than $V_{rms}^2/R1$, where V_{rms} is the RMS voltage across the load.

Bridge Configuration

The output voltage range can be doubled to ± 200 V by driving the load in a bridged configuration as shown in Figure 9. In this configuration, the output voltage is

$$V_{out} = 40(V_{in} - 5)$$

That is, a 0V to 10V input produces ± 200 V at the load. Zero volts across the load occurs when the input voltage is +5V. However, note that the absolute voltage of each terminal is still +100V.

The power bandwidth for this configuration can be calculated by considering only one amplifier and doubling the effective capacitance.

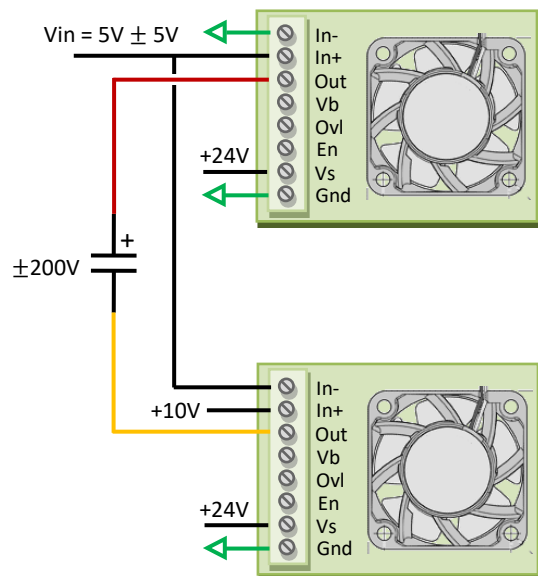

Figure 9. Bridge configuration achieving ± 200 V

Safety

This device produces hazardous potentials and should be used by suitably qualified personnel. Do not operate the device when there are exposed conductors.



Parts of the circuit may store charge so precautions must also be taken when the device is not powered.

Dimensions

The mounting posts accept M3 screws. For the PCB mounting version (MX200-PCB), a schematic and footprint library is available for Altium Designer. Refer to the online product details.

Contact / Support

info@piezodrive.com

Revision History

Date	Rev	By	Changes
23/03/21	R4	KB	Added bipolar output info
21/01/21	R3	KB	Updated figure style
16/01/21	R2	KB	Temp range updated

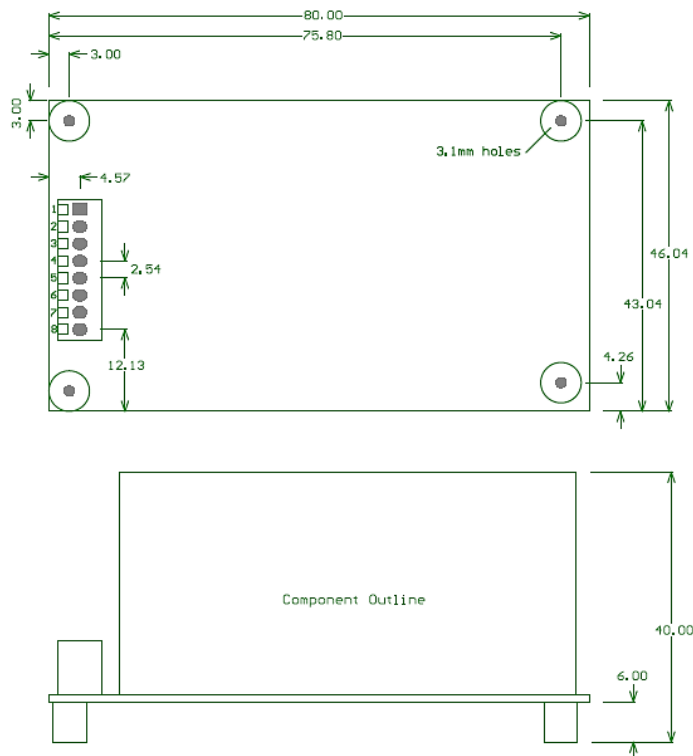

Figure 10. Dimensions (mm)